

Cabinet Lighting Systems



CABINET | LINEAR | TASK | MOOD

Selection and Installation Guide 2010

KICHLER 
LIGHTING

Custom lighting systems are one of the key ingredients needed to successfully layer light in a living space. Residences and light commercial spaces typically contain recessed ceiling and surface mounted lighting fixtures. A complete lighting package should also include lighting systems to properly layer the light and provide the homeowner/user a variety of lighting options to create the environment that best suits the moment.

Included in this guide is assistance on what to light, how to light it, how to select the correct lighting for each task and detail suggestions on how best to install the lighting once selected. This guide should be a companion to the Kichler Lighting full line catalog and the specific installation instruction included in each carton. Together, they will allow you to plan, layout, specify and install your lighting system. There are also a number of tips included to help your installation look and perform at its best.



Kitchen with undercabinet, over cabinet and toekick lighting along with overhead pendant accent lights. Exhaust fan carries its own lights and glass front cabinets all have a light inside, but are turned off in this photo.

Table of Content

What Should I Light?	Page 4
How Should I Light, What I Want To Light?	Page 7
The Options – Fixture Types	Page 12
• Modular	Page 12
• Direct Wire	Page 13
• Pucks/Discs	Page 15
• Linear	Page 16
• Plug-In	Page 17
The Options – Lamp Types	Page 18
• LED	Page 18
• Xenon	
○ 12 Volt (low-voltage)	Page 18
○ 120 Volt	Page 19
• Halogen	Page 19
• Fluorescent	Page 19
The Kichler Options Matrix	Page 20
Planning a Modular Installation/ Creating a Bill of Material	Page 21
• LED	
• Xenon	
Planning a Direct Wire Installation/ Creating a Bill of Material	Page 27
Planning a Puck/Disc Installation /Creating a Bill of Material	Page 30
• LED	
• Xenon	
Planning a Linear System/ Creating a Bill of Material	Page 35
• LED	Page 35
• Xenon	Page 40
Installation Tips	Page 44
• Modular	Page 44
• LED Disc System	Page 45
• Interconnect Cable Notches	Page 46
• Frequently Asked Questions	Page 47
Sample Kitchen Layout Sketches	Page 54
• Galley (Straight)	Page 55
• “L” Shaped	Page 56
• “U” Shaped	Page 57

What Should I Light?

It is a good idea to think about lighting a space, before construction or remodeling begins. Often times, the choices made impact the placement of wires and careful planning can avoid added costs, rework or contractor call-backs. Determining what to light might be easier if you think about how the space will be used and what mood or moods you are seeking to achieve. Use the sections in this chapter to help you determine what element would benefit from light. Remember, you're better off with more than less light. With individual switches, you can always control or reduce the amount of light in a space. Once the walls are in place, it is usually difficult to add more light without incurring added expense and complexity.

Under Cabinets

Under cabinet lighting is one of the foundations of a well lit kitchen. Upper cabinets, by nature block a great deal of the ceiling light, creating shadows. When using the counter, people also block a percent of the available ceiling light. Supplemental light, unaffected by shadows is crucial to a usable and viable counter area. That light comes from under cabinet lighting fixtures.

In many cases, under cabinet lighting is also used as a night light for the kitchen. Rather than burning all the high-wattage ceiling units, cabinet lights, even at a low level, (if they are equipped with a multi-level switch) will provide adequate light for most evening activities.

If you do nothing else, undercabinet lighting should be included in every kitchen design.

It is also important to remember that cabinets are being installed in a number of areas outside the kitchen. Don't forget cabinet lighting in the garage, laundry room, pantry and closets.

Over Cabinets

If the kitchen is equipped with a soffit over the cabinets, lights are impossible. If however there is an open space between the cabinet top and ceiling, lights in this area can add an element of intrigue and interest. Often times, the space on top of the cabinets is used to display collectables or is filled with plants. Lights spotting the items we care about or soft backlighting to set off the foliage can make a

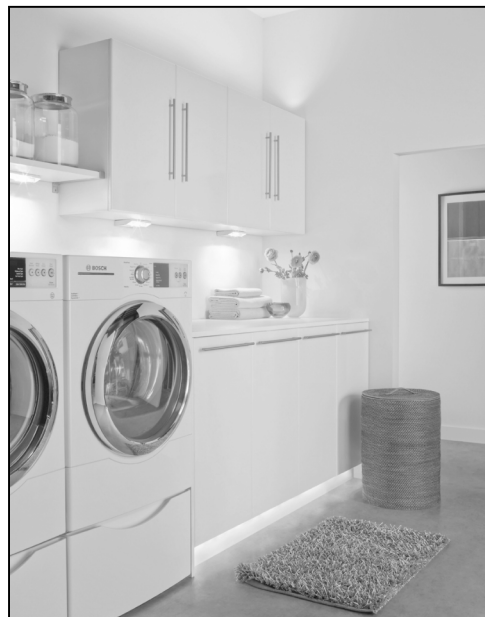

Laundry room with over cabinet, under cabinet, under shelf and toekick lighting

tremendous visual difference. If the kitchen is small, lighting over the cabinets will help to visually expand the room and give the illusion of a much larger room. Remember, 24" countertops subtract two feet from each side of the room! That space can be regained, with light.

Inside Cabinets/Inside Drawers

Cabinets with translucent doors can benefit from lit interiors. If the door is clear, the light will nicely illuminate the items you have displayed inside. If the door front is etched, patterned or in some way obstructed, the soft glow emanating from the cabinet will add an element of drama to the room. In some cases, cabinets with opaque doors can benefit from lit interiors. When the space is too dark, the light can be helpful. If shelving is translucent, it becomes even more useful. If you choose to do this however, it may be wise to investigate switching triggered by the opening and closing of the cabinet door.

With the exception of those used for display, most cabinets function well with a low level of light. If a cabinet contains crystal, higher levels might be desired to showcase the cut and color.

To avoid misplacing key utensils and important kitchen gadgets, lighting inside a drawer could be considered. If you choose to do this, it may be wise to investigate switching triggered by the opening and closing of the drawer.

Under Counters

Lighting concealed under the edge of a counter can be an effective way to illuminate the interior of drawers, when they have been extended. It also serves to set off the architectural edge of the counter.

Under-Counter lighting is a relatively new concept. If this is a lighting option under consideration it may be wise to discuss concealment options with the countertop contractor.



Cabinet area with above cabinet lighting, inside cabinet lighting and lighting under each shelf

Toekick Lighting

Toekick lighting can be a great way to define the baseline edges of cabinets. It can also serve as a great nightlight, preventing accidents and adding intrigue to a room. Properly positioned, toekick lighting gives the visual illusion of floating cabinetry and can add depth to interesting floor covering. In dimly lit spaces, the subtle light will define the room's architecture while providing added safety.

Under Tables/Benches

Adding light under tables and benches will visually enlarge the room. The dark spaces that disappeared into the corners will now come alive. Illuminating these unusual areas will set the room apart and draw interest to the space.

Coves/Tray Ceilings

Illuminating coves that travel around the perimeter of a room will draw attention upward forcing one to appreciate the full room. It also elongates the walls to give added dimension to the room. Tray ceilings are typically a mastery of millwork. Detail has been included to move away from the drab, flat slab of white. With the addition of lighting at one or more levels of the tray, the craftwork can be shown and admired.

Both of these architectural details can be lit well with low lumen levels. This is not light with which to read, but instead light that helps define the architecture, the space and provides visual enhancement of the living area.

How Should I Light, What I Want To Light?

Now that you have taken inventory of your home and have determined which of the many areas should be lit, the correct method of lighting needs to be determined. All of the suggested areas listed in the previous section have been brought into this chapter. Following the broad groups is the best method for lighting them and an explanation why. Also included are secondary and in some cases tertiary suggestions with the pros and cons indicated. Advice on the use is also included.

Use this information to determine the correct lighting fixture. Refine that choice by reviewing the pros and cons for each lamp source.

Under Cabinets

Best Choice

The most functionally helpful lighting for under cabinet use is a modular system that allows for the placement of the fixtures at the FRONT edge of the upper cabinet. Fixtures at the front put light on the front of the counter, where it is needed for all of the basic food preparation functions.

Fixtures engineered for use as Direct Wire can be configured by the installer/electrician for forward mounting, but in most areas, this would entail the use of conduit or metal sheathed cable. Often times, this metal tubing is considered unsightly and the smaller cable used on modular systems is preferred.



Kitchen with modular Xenon undercabinet lighting and directional linear light over the cabinet to backlight the collectables assembled overhead.

Alternate Choices

Cabinet lighting mounted at the rear surface of the underside is an adequate alternate. The biggest deficiency with this type of installation is light placement. The light is brightest at the back of the counter and on the backsplash wall. Less lumens of usable light can be projected to the front area of the counter where light is needed the most.

Often times, rear mounted, or Direct Wire type fixtures are used because the electrician has pre-wired the area long before the user or kitchen design professional has defined the light source. When the cabinet installation professionals arrive, they understand how to adapt what the electrician has provided. It is vitally important that intent and desire is expressed prior to any tradesperson starting work or preference may not be possible.

Another alternate that works reasonably well in under cabinet situations is linear lighting. The light can be mounted in almost any location, so illumination at the front of the counter is possible. The only negative can be the amount of light available. Linear lighting does have minimum spacing and maximum wattage numbers that must be considered. You may not have enough light if a linear system is selected.

A final alternate for undercabinet lighting is a puck/disc system. Visually, this is an appealing choice. The discs are small and in some cases more attractive than linear units. This light is somewhat more directional and a decision will need to be made on spacing, but the light can be effective. This is a good choice if the installer wants to play with light arrays to make a more decorative statement in place of functional preference.

Regardless of which system is selected for under cabinet lighting, it is important to follow a few simple rules:

- Use a length (or quantity) commensurate with the size of the cabinet. You want to fill the full length of the cabinet with light, of course allowing space for accessories and attachments.
- Avoid dark spots. Install a lighting unit under each cabinet section. Don't skip one, assuming the light will spill over to the neighboring area.
- Avoid dark spots. They will make the countertops look uneven.

Over Cabinets

Best Choice

Linear lighting is the best choice for over cabinet illuminations. In this application, the effect of the light is more important than the lumen output, so equal spacing should be a priority in order to provide the most even flow of light. Many linear lighting systems offer the ability to add directional reflector (spot) accent lights. This lamp type is valuable when attempting to draw attention to artistic or collectable elements positioned in the space over the cabinet. Running a separate system is not required.

Alternate Choices

A Direct Wire or Modular lighting system will work for over cabinet lighting. Depending on the user and application, it might actually be preferred. You will generally get more light from an enclosed fixture and it will likely be easier to keep clean in these dust-prone areas. If this type fixture is included, it is important to link them end-to-end to avoid black spots or light voids. It is likely that this lighting solution will be more expensive than linear.

Inside Cabinets/Inside Drawers

Best Choice

There are two very good options for lighting the inside of cabinets. The choice really depends on what is the illumination goal. Linear lighting will provide a soft even glow of light that fills the entire cabinet. Disc lights will be more directional, almost like a spotlight. They will punch a concentration of light onto the items in the cabinet. If you have a few collectables or art pieces in a cabinet, the disc lighting is the best bet. If you have filled a cabinet with colorful, but everyday dishware, the soft glow of Linear lighting would work better.

Lighting the inside of drawers can only be achieved with linear lighting. There is very little space inside a drawer and a low profile linear system may be the only one that fits. It is important, if this type lighting is planned to clearly map out placement and switching. Position of wire is also crucial to avoid being pinched by the drawer movement. These are tight spaces and care must be taken. Discuss this option carefully with the cabinetmaker to determine if he or she has experience lighting and wiring these interiors.



*Cabinet interior
lit with Xenon
Disc, one in each
side*

Under Counters

Best Choice

Illuminating the underside of a counter edge can only be accomplished with linear lighting. There is typically a minimal amount of space between the counter edge and the extended drawers. Linear lighting with a minimal profile is likely to be the only light source small enough to fit in these tight areas.

When planning the installation of lighting for the counter's edge, it is advisable to have a conversation with the manufacturer of the counter. Accommodations such as routed undersides, extended edges, added skirts and raceways may aid in

the installation and concealment of fixtures and wire. A larger than normal space between counter and drawer might also be needed.

Toekick Lighting

Best Choice

Because of the tight space confines and minimal clearance, linear lighting is really the only viable option for Toekick lighting. Because the light source is reasonably close to the reflective surface (the floor) you should expect to see light patterns and beams. Lower wattages will ameliorate some of these defined pools so it may be wise to select wattage and lumen output that is reasonably low. The key in this lighting type is its service as an accent and NOT its value as functional light.

Under Tables/Benches

Best Choice

Because of its ability to hide well, linear lighting is probably the best choice for installation under tables and under benches. The nature of linear lighting allows it to emit a softer glow that you might expect from alternate light. It is also typically a lower wattage and that is considered preferable.

Alternate Choices

Modular lighting systems can be used in these applications as well. The self-contained units can be a clean and simple way to add light without the complexity of a linear system. If modular fixtures are used, care should be taken to avoid a spotty or inconsistent light effect.

If a more deliberate pool of light is desired, disc lighting can create an effective design element. Rather than an even glow of light, disc will create a “spot light” effect that can be interesting.

Lighting added under tables and benches should likely be power with portable plug-in power cords, not hardwired unless they are permanently built-in furniture pieces.

Coves / Tray Ceilings

Best Choice

Linear lighting is the only real option available to illuminate coves or tray ceilings. Because of their tight spaces and lack of access, small flexible lighting systems must be employed. Key to effective cove and tray lighting is consistent and even light. Lamping should be spaced equidistant, unless an array effect is the goal. Higher wattages will tend to distribute a spotty result. In general, lower wattages do a nice job illuminating these areas.

Other Places?

There are a number of locations where light can generate excitement and interest. If you can think of a place, it is likely that light can be added. Think about walk-in closets, bedrooms, pantries and garages. If there is an idea, consult with a lighting professional and ask if they can help.

It is likely they will find a way to light almost anything.



Bedroom with LED Linear light under the platform, around the headboard and above each shelf in the recessed wall surround.

The Options – Types of Installations

There are a number of system options that will work to illuminate what is desired. This section will help define the benefits, pros and cons of each so the correct system can be employed.

Modular Systems



Modular systems are characterized by their flexibility. Wiring to the home's power source is handled in a separate unit. Power to the lighting fixture is carried via a cable. The lighting fixture can then be placed at the optimal position, unconstrained by the location of the power.

The creation of a modular system allows for lighting fixtures to connect in a string, one after another. The cables that connect each unit bring power from one to the next. Switches and other available accessories can be positioned in the location most favorable to the room or end user accessibility.

Modular Systems Pros

- Allows the lighting fixtures to be mounted at the front of the cabinet or anywhere that insures better light at the working space
- If the installation is unusual, the flexibility of mounting can usually conquer any installation challenges.

- Connecting a continuous series of light fixtures across an area is simple. Power is transferred via a connection cable that is plugged into each end of the light fixtures.

Modular System Cons

- A modular system is a bit more complicated to install. Once installed, there are exposed cables that some people find undesirable. (This can, however be ameliorated by tucking the wire as tight to the underside corners as possible. Proper use of wire clips also helps.)
- Modular systems are more expensive than a Direct Wire solution employing the same lamping technology.

Direct Wire Systems



Direct Wire light fixtures are self contained. All of the elements needed to operate the light are contained within. They require a separate 120V power feed for each unit and have minimal placement flexibility because of that hard-wired connection to power. In order to insure that they will be positioned in the correct place, the electrician will need to know where each unit is planned prior to the installation of the cabinetry. During cabinet hanging, the installer will bring the electric through the cabinet's back lip.

Direct Wire System Pros

- Less expensive
- If using a single fixture, they are easier to install
- This is the under cabinet system most familiar to an electrician/installer

Direct Wire System Cons

- Mounts along the back edge of the cabinet's underside, placing more light on the back wall and less light on the front of the counter, where it is most needed
- If front mounted is desired, most electric codes require the use of conduit or sheathed flexible cable, both of which have a somewhat undesirable appearance, or a bulky size, if routed inside a cabinet.
- Linking a continuous string of direct wire light fixtures involves snapping out the side KO's on each fixture, adding threaded nipples and nuts or some sort of raceway hole protector before running wire from fixture to fixture
- If desire is not communicated to the electrician, wires will be installed as they see fit. Be certain light location is carefully discussed with the electrician prior to the start of the job.

Discs/Puck Systems

Employing a Light Disc or “Puck” system is much like the modular system, in that a number of pieces are required to properly place, install and function. The central reason for using discs or pucks is their ability to pinpoint light and the compact physical size of the light fixture. These installations typically require a bit of planning and are somewhat more complicated to install.



Disc/Puck System Pros

- Compact size – Xenon or halogen are approximately 2 ½” diameter by 1” deep. LED discs are 3/8” deep
- Discs employing LED light technology run cool and can be very small (3/8” deep) and do not need to be recessed into most cabinets
- Light is concentrated in a small compact area, perfect for highlighting collectables and art pieces

Disc/Puck System Cons

- Complex installation, especially if Xenon puck is flush-mounted into cabinet top. This will require a wood bore hole.
- Pucks operating halogen lamps can become very warm during installation.

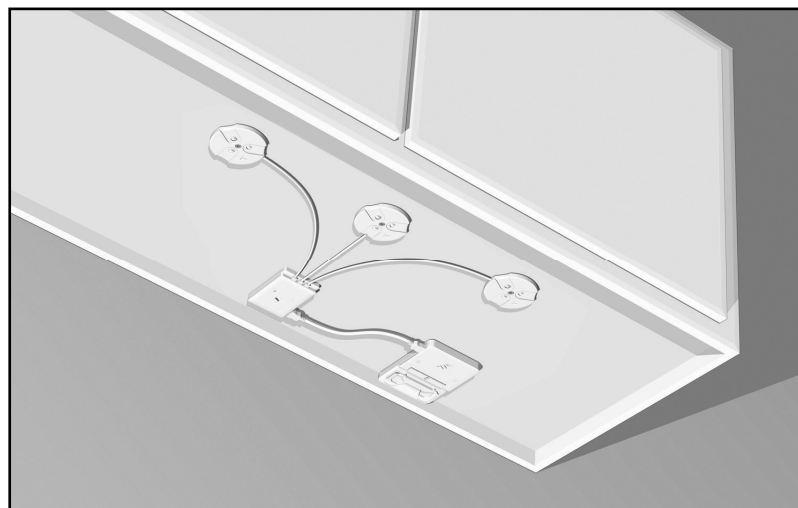

Linear Lighting Systems

Linear lighting systems might better be called “Architectural Detail Lighting.” The intent of these systems is to add dramatic punch to a room or a space with the use of light. The key here is to hide the light and see the effect.

Linear lighting systems are small and compact and designed to hide. Systems should be planned in advance so all of the components are ready and available for installation. Installations can be complicated, because they often involve tight, small spaces.

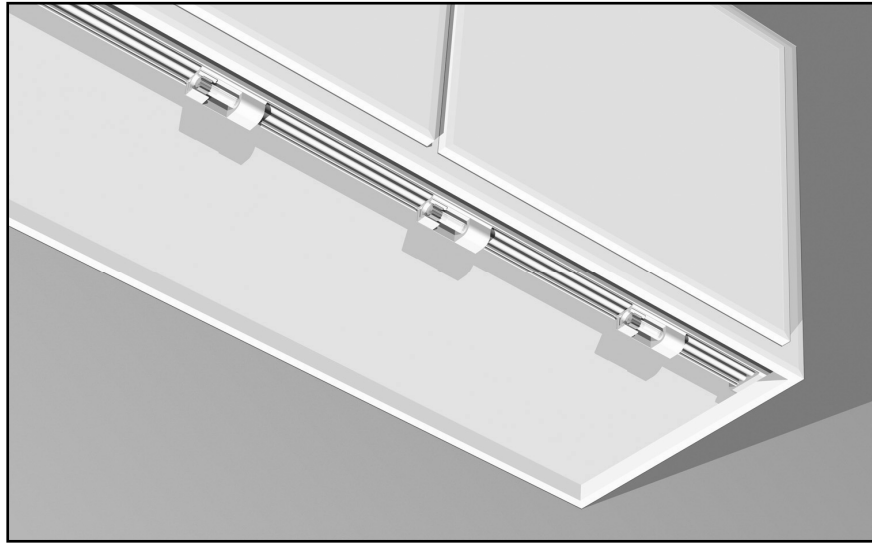

Linear Lighting Systems Pros

- Small, compact light source

Linear Lighting Systems Cons

- Installation is complicated
- Most are added to small spaces with minimal physical access
- Careful planning is essential

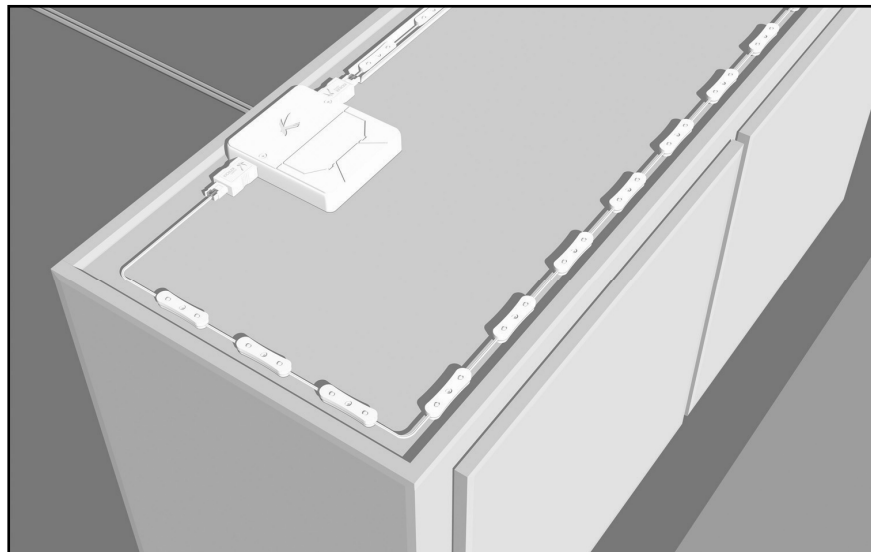

Plug-in Option

The permanently installed modular, Direct Wire, Linear and Disc/Puck systems can be powered with a cord and plug option. This should, however only be used as the last resort. Hiding the wire behind the walls will always result in the cleanest look. A cord dangling down from a cabinet looks unkempt and unplanned.

On the contrary, a plug-in option for use on portable furniture is the best idea (for example, the inside of an armoire or cabinet). It is impossible to properly feed 120V wire into furniture. Cord and plug power is safe and viable in these instances. It is important to remember that a Grounded Convenience Outlet (GCO) is needed nearby.

Cord and plug accessories are available for most systems.

Types of Lamping

There are five primary lamping options used in custom lighting systems:

- LED
- Xenon Low-Voltage
- Xenon Line (120) Voltage
- Halogen
- Fluorescent

Following is a brief list of positive and negative aspects of each. This Pro and Con listing should help in the decision making process of selecting the correct fixture enclosing that lamp for each task.

LED Pros & Cons

- + Pros +
 - Long life 40,000 hours
 - Energy Efficient
 - No/Low Maintenance
 - VERY cool operation
 - Smaller size on some models
 - Can be Energy Star listed
 - Lifetime cost to operate is low
- - Cons -
 - Initial price of lighting unit
 - Must understand Color Temperature and CRI to effectively choose the correct unit
 - Vulnerable to overstated performance

12 Volt Xenon Pros & Cons

- + Pros +
 - Long life 10,000 hours
 - Warm (not hot) operation
 - Moderate price
 - Very good light levels
- - Cons -
 - Warm (not hot) operation
 - Transformer (typically included) is needed for operation
 - 1" minimum depth needed on most fixture enclosures
 - Moderate price

120 Volt Pros & Cons

- + Pros +
 - Price
 - Direct 120V wire connection. No transformer included
 - Lightweight
- - Cons -
 - Short lamp life (2500 hours)
 - Fixture is bigger, 1 ¼” minimum depth typically required on fixture lamp enclosure
 - Lower lumen output than 12V version

Halogen Pros & Cons

- + Pros +
 - Moderate price
 - Good light levels
- - Cons -
 - Very hot operating temperature
 - Usually needs more than 1” lamp enclosure on the fixture to dissipate heat and operate at correct temperatures
 - Lamp and fixture maintenance – because of high operating temperatures, there is heavy wear on the lighting unit and light source

Fluorescent Pros & Cons

- + Pros +
 - Long life
 - Energy Efficient
 - Lowest Price of most cabinet lighting options
 - Can be Energy Star listed
- - Cons -
 - Must understand Color Temperature and CRI to effectively choose the correct lamp

The Kichler Options Matrix

A quick visual reference to help you select the best option for the job and budget

Type of Lighting Fixture	Design Pro LED Modular	Task Work Modular 12V Xenon	Task Work Modular 120V Xenon	Task Work Modular 120V Fluorescent	Design Pro LED Direct Wire	Task Work Direct Wire 12V Xenon	Task Work Direct Wire 120V Xenon	Task Work Direct Wire Fluorescent
Light at Front Edge of Counter	√	√	√	√				
Longest Lasting Lamp Life	√				√			
Energy Efficient	√			√	√			√
Coollest Operation	√				√			
Low Maintenance	√				√			
Mounts to Rear Underside of Cabinet					√	√	√	√
Budget Priced							√	√
Less Than 1" Profile	√							
Requires Understanding of Color Temperature and Color Rendering	√			√	√			√
Captive Screw Mounting	√	√						
Keyhole Mounting			√	√	√	√	√	√
Multiple Finishes Available	√	√	√		√	√	√	
Extended Warranty	√				√			

Planning a Kichler Modular System Installation

The installation of a modular system is more complicated and so, it requires a bit more pre-planning. The effort spent beforehand will result in a far more dynamic look once finished.

Determine Fixture Size and Quantity

First, decide where each lighting fixture will be placed. Determine the length of each fixture intended for each area. Remember, that modular fixtures can be connected together. If you need a 30" unit and only a 12" and 18" are offered, the two can easily be connected. Also, allow space for accessories and the interconnect cable ends. They will consume some of the available undercabinet space.

Here is a step-by-step example to arrive at the correct length for each location.

1. The cabinet width is 30" (nominal)
2. The space under the cabinet suitable to accommodate lighting is 28 ½"
3. This is the first cabinet, so the power cord will be making a 90° turn in order to bring power into the first fixture. A 12V Xenon or 120V Modular Fluorescent system will need 2 5/8" to make the turn. A 24V LED cable will need 2 1/8" to bend. Include these sizes in the calculation.
4. If the opposite end of the fixture will be connected to another fixture in the next cabinet section, allow space for the interconnect cable end plug. 1 ¾" is needed for the 12V Xenon or Fluorescent system. 1 5/16" is needed for the 24V LED plug.
5. The interconnect cables come in specific lengths. They cannot be shortened, so the wire will need to be tucked into the available underside space.
6. The remaining available space is 24 9/16". The manufacturer offers a 22" unit. They also offer a 12" unit. Two 12" pieces would also work. Select one of these options for this cabinet section.
7. Consider whether a master control switch or a night light module will be used in the system. If so, you will need to subtract these widths in the cabinet section where it is intended for installation. This may change your calculation or the size of the lighting fixture selected.
8. Repeat this process for each section that is to be illuminated.
9. Compile a list of the fixture size and quantity.

Use this form to calculate the length needed for each cabinet section:

- _____ cabinet width
- _____ underside cabinet width (cabinet width minus the wood thickness on each side)
- _____ Is this the first cabinet? – Subtract 2-5/8” for Xenon/Fluorescent or 2-1/8” for LED
- _____ Interconnect cable on the left side? – Subtract 1-3/4” for Xenon/Fluorescent or 2-5/16” for LED
- _____ Interconnect cable on the right side? – Subtract 1-3/4” for Xenon/Fluorescent or 2-5/16” for LED
- _____ Will an on-off switch be added to this cabinet section? – Subtract 3-1/2” for Xenon/Fluorescent Master Switch or 1-3/4” for LED
- _____ Will a Night Light be added to this cabinet section? – Subtract 1-3/4” for LED
- _____ Total available space for the under cabinet lighting fixture. Compare this number with the sizes available in the style desired.

Interconnect Cables

To link power from one fixture to the next, interconnect cables will be required. Determine the space between each fixture and match that requirement to the lengths of interconnect cable offered. For example, if the space between two fixtures under adjoining cabinets is 6”, select the 7” interconnect cable. Compile a list of needed sizes.

If a continuous flow of power is desired with the LED installation, a 10’-0” interconnect cable is available for installation behind walls, over sinks, over microwave enclosures or in any area where extended lengths are required.

Interconnect cables can be plugged together to extend their length. It may be advisable to knot the cords prior to plugging to insure they do not come apart, if the joint is installed in areas where the wires might be subjected to mishandling.

Bringing Power to the Lighting

Determine from where the power will originate. Will you have one location for electric power or multiple?

Xenon and Florescent Modular Power

A Xenon and Florescent Modular system is powered via an under cabinet mounted power module. Romex or sheathed cable is pushed into the module and wired. Interconnect cables bring power from the module to the fixtures.

LED Power

Power can be brought into an LED system in one of three ways, remote, Undercabinet mounted supply or plug-in. following are the benefits and detractions of each.

1. The remote power supply is the cleanest installation with the least amount of visual encumbrance. Once installed, only the power supply cable will be visible. The power supply unit is installed elsewhere, so it can be hidden in a lower cabinet, the basement, the attic or atop the cabinets. Cable is rated for Class 2 installations, so it can travel inside the walls to the undercabinet surface. It is best if ultimate location of the remote power supply is planned in advance. A “fish line” may be employed to aid in the passage of wire, once the walls are in position. A power supply cable is needed for this type installation and can be installed in the wall ahead of time, if desired.
2. An undercabinet mounted power supply can be used if power has already been installed. It functions much like the Xenon wire module in that the building’s source wire is pushed into the wiring compartment, a wire connection is made and it is read to power the light fixture. Because of the size, this unit may have an undesirable aesthetic appeal once installed. In over cabinet applications, this type of power supply will not be noticed and can be an effective method to adding light.
3. The modular systems can be powered with a cord and plug option. This should only be used as the last option. A cord dangling down from a cabinet looks unkempt and unplanned.

Selecting the Size of the Power Supply (LED Modular Only)

The various power supply methods are limited by a defined wattage maximum capacity. To be certain that the power supply will properly run the system, total wattage must be calculated. Remember to total ALL fixtures, switches and night light modules to arrive at the total system draw.

Switch Controls

Decide if a wall switch to control the lights is desired. Remember, that most cabinet lighting fixtures have a switch installed in the individual fixture. Many systems also have a switch that will control the entire, wired together system. If a wall switch that is configured into the 120 volt house current is also needed, this should be discussed with the electrician prior to the installation of the lighting fixtures.

A master switch is available for the Xenon and Florescent Modular system. A dimming switch is available for the LED systems. Determine what is needed.

Night Light Module

A night light is available for the LED systems. Determine if one or more are needed.

Check List and Spec List

Use the following list to insure proper communications prior to the job, all the parts needed for the job are captured and the installation is as expected afterwards.

Modular Cabinet Lighting System Check List and Spec List

Prior to the Job:

- Discuss the desired undercabinet lighting system with the electrician.
- Discuss the desired power supply system with the electrician.
- Plan placement of the remote power supply.
- Plan placement of interconnect cables that need to be buried behind the walls PRIOR to drywall installation.
- Discuss the desired 120V power switching needed with the electrician.
- Discuss the undercabinet lighting system with the cabinet designer, retailer and installer.

Spec List 12V Xenon Modular System [TaskWork Modular 12V Xenon]

Description	Part No.	Finish	Qty	Location (N,S,E or W wall)
1lt 7" fixture	10565	BRZ,NI, WH		
2lt 13" fixture	10564	BRZ,NI, WH		
3lt 22" fixture	10563	BRZ,NI, WH		
4lt 30 ½" fixture	10587	BRZ,NI, WH		
9" cable	10571	BK, WH		
14" cable	10572	BK, WH		
21" cable	10573	BK, WH		
Master Switch	10569	BRZ,NI, WH		
Wire Module	10570	BK, WH		
Plug-in Master Switch	10575	BRZ,NI, WH		
Replacement Bulbs	10574	CLR		

Spec List 120V Xenon Modular System [TaskWork Modular 120V Xenon]

Description	Part No.	Finish	Qty	Location (N,S,E or W wall)
1lt 7" fixture	12211	BZ, SS, WH		
2lt 13" fixture	12212	BZ, SS, WH		
3lt 22" fixture	12213	BZ, SS, WH		
4lt 30" fixture	12214	BZ, SS, WH		
5lt 40" fixture	12215	BZ, SS, WH		
9" cable	10571	BK, WH		
14" cable	10572	BK, WH		
21" cable	10573	BK, WH		
Wire Module	10570	BK, WH		
Replacement Bulb	12090	CLR		

Spec List Fluorescent Modular System [TaskWork Modular 120V Fluorescent]

Description	Part No.	Finish	Qty	Location (N,S,E or W wall)
8-W 12" fixture	10026	WH		
13-W 21 ½" fixture	10027	WH		
21-W 33 ½" fixture	10028	WH		
9" cable	10571	WH		
14" cable	10572	WH		
21" cable	10573	WH		
Master Switch	10569	WH		
Wire Module	10570	WH		
Plug-in Master Switch	10575	WH		

Spec List LED Modular System [Design Pro LED Modular]

Description	Part No.	Finish	Qty	Location (N,S,E or W wall)
4-W 6" fixture	12301	BRZ, NI, WH		
7-W 12" fixture	12303	BRZ, NI, WH		
10-W 18" fixture	12305	BRZ, NI, WH		
9" cable	12341	BK, WH		
14" cable	12342	BK, WH		
21" cable	12343	BK, WH		
10'-0" cable	12344	BK, WH		
Dimming Switch 1-W	12350	BK, WH		
1- W Night Light	12351	BK, WH		
Remote Power Supply 100W	12380	BK		
Remote Power Supply 200W	12382	BK		
Under Cabinet Power Supply 50W	12353	BK, WH		
Power Supply Lead 8'-0"	12344	BK, WH		
Power Supply Lead 25'-0"	12346	BK, WH		
Plug-in Power Supply 30W	12383	BK, WH		
Plug-in Power Supply 60W	12384	BK, WH		
Double Female Connector	12348	BK, WH		
Double Male Connector	12348	BK, WH		

Planning a Kichler Direct Wire Installation

The installation of a Direct Wire is easier than a Modular System. While you save on the installation process, you lose a bit in light output and placement of light. Carefully decide if a Direct Wire system is best suited for the application and user.

Determine Fixture Size and Quantity

First, decide where each lighting fixture will be placed. Determine the length of each fixture intended for each area. In general, it is advisable to install one direct wire unit per cabinet.

Here is a step-by-step example to arrive at the correct length for each location.

1. The cabinet width is 30" (nominal)
2. The space under the cabinet suitable to accommodate lighting is 28 ½"
3. The manufacturer offers a 22" unit. They also offer a 12" unit. Two 12" pieces would also work. Select one of these options for this cabinet section.
4. Repeat this process for each section that is to be illuminated.
5. Compile a list of the fixture size and quantity.

Bringing Power to the Lighting

Direct Wire cabinet lighting is assembled to power wire stubbed out under each cabinet section. Because they are typically wired in series, there are usually two sets of wires one for power to come in and one to take power to the next fixture. When installed, the electrician will make the appropriate wire connection. The location of the last unit will have only one set of wires, as power will not be jumped to another unit in the series.

If two fixtures are to be "butted together" to achieve a longer flow of continuous light, wire will need to pass from one fixture to the next by knocking out the knock-outs on the fixture's ends, adding a nipple, hexnut and lockwashers.

Be certain that 120V wire is planned for EACH section of cabinet that light is desired.

Switch Controls

Decide if a wall switch to control the lights is desired. Remember, that most cabinet lighting fixtures have a switch installed in the individual fixture. If a wall switch that is configured into the 120 volt house current is also needed, this should be discussed with the electrician prior to the installation of the lighting fixtures.

Check List and Spec List

Use the following list to insure proper communications prior to the job, all the parts needed for the job are captured and the installation is as expected afterwards.

Direct Wire Cabinet Lighting System Check List and Spec List

Prior to the Job:

- Discuss the desired undercabinet lighting system with the electrician.
- Plan placement of wire that needs to be buried behind the walls PRIOR to drywall and cabinet installation. Know where you want fixtures and communicate that desire to the electrician.
- Discuss the desired 120V power switching needed with the electrician.
- Discuss the undercabinet lighting system with the cabinet designer, retailer and installer.

Spec List 12V Xenon Direct Wire System [TaskWork Direct Wire 12V Xenon]

Description	Part No.	Finish	Qty	Location (N,S,E or W wall)
1lt 7" fixture	10579	BZ, SS, WH		
2lt 12 ¼" fixture	10580	BZ, SS, WH		
3lt 22 ½" fixture	10581	BZ, SS, WH		
4lt 30" fixture	10584	BZ, SS, WH		
5lt 40" fixture	10595	BZ, SS, WH		
Duplex BX Cable Connector	10588	SI		
Replacement NM & BX Cable Connector	10589	SI		
36" Cord & Plug	10582	WH		
Replacement Lamp	10574	CLR		

Spec List 120V Xenon Direct Wire System [TaskWork Direct Wire 120V Xenon]

Description	Part No.	Finish	Qty	Location (N,S,E or W wall)
1lt 7" fixture	12011	BZ, SI, WH		
2lt 12" fixture	12012	BZ, SI, WH		
3lt 22" fixture	12013	BZ, SI, WH		
4lt 30" fixture	10584	BZ, SI, WH		
Replacement Lamp	12090	CLR		

Spec List Fluorescent Direct Wire System [TaskWork Direct Wire 120V Fluorescent]

Description	Part No.	Finish	Qty	Location (N,S,E or W wall)
8-W 12" fixture	10041	WH		
13-W 21 1/2" fixture	10042	WH		
21-W 33 1/2" fixture	10043	WH		
28-W 46 1/2" fixture	10544	WH		
Duplex BX Cable Connector	10588	SI		
Replacement NM & BX Cable Connector	10589	SI		
36" Cord & Plug	10582	WH		

Spec List LED Direct Wire System [Design Pro LED Direct Wire]

Description	Part No.	Finish	Qty	Location (N,S,E or W wall)
4-W 6" fixture	12051	BZ, SS, WH		
6.4-W 12" fixture	12052	BZ, SS, WH		
9.3-W 22" fixture	12053	BZ, SS, WH		
12.4-W 30" fixture	12054	BZ, SS, WH		
Duplex BX Cable Connector	10588	SI		
Replacement NM & BX Cable Connector	10589	SI		
36" Cord & Plug	10582	WH		

Planning a Kichler Disc Installation

The installation of a disc system is driven by the desire to accent item and less as a task source. Careful planning of fixture and wire placement is essential, so the light is seen, but the light fixture disappears. This beforehand effort will result in a far more exciting look once finished.

Determine Fixture Quantity

First, decide where each lighting fixture will be placed. Break this task into the areas that will be lighted.

Inside cabinet – One per cabinet door will typically work best. If the doors are especially small, a single disc for the double door cabinet will work. If the cabinet is especially wide, a third may be needed.

- Small cabinets to 15" – 1 disc
- 16" to 32" cabinets – 2 discs
- 33" to 48" cabinets – 3 discs
- Large Cabinets – approximately one every 12"

Under Cabinets – if disc lighting is used under a cabinet, there will be an element of task use involved. Because of the wide variety of cabinet widths, it is difficult to define exact spacing. Here are a few guidelines to insure adequate lighting.

- Try for spacing somewhere between 9" and 15" on center.
- If multiple cabinets are being lit, try to keep similar spacing under each cabinet area. For example, try for a 9" to 11" spacing for all cabinets in the room or a 14" to 15" spacing around all areas in the room. If, in one area discs are spaced at 9" center-to-center and the next is spaced 15" center-to-center, the latter will look darker than the former.
- Try for symmetry under the cabinet. Perhaps one disc under each cabinet door will provide a balanced look. If that exceeds the 15", consider one on the cabinet centerline with a pair equidistant from the centerline.
- General task lighting will be better if the fixtures are located toward the front edge of the cabinet.
- Drama can be created by placing the lights closer to the rear (against the backsplash) causing the light to array against the wall, thus creating a scalloped pattern. Keep in mind this will be a less effective task light source.

Plan Wire Placement

Disc lighting is typically used in very visible locations. If this is the case, careful planning of the wire is crucial to a well perceived installation. Before drilling holes or wire placement routing, consider the viewers point of view. When a typical viewer looks into the cabinet, what can they see? If the area to the left and right is visible, plan on routing the wire to the rear. If the space above the shelf is not

visible to the viewer, then consider routing the wire through the top of the cabinet to an area non-visible to the viewer. Routing wire to the forward portion of the cabinet or shelf is usually less noticeable than the rear.

If wire visibility is questionable, cut a length of yarn and tape it to the proposed path inside and around the cabinet. If you can see the yarn, you will see the wire. Look for a routing method that will be the least visible.

The Xenon disc fixtures are provided with 72" of 18 gauge single strand wire. The individual wire must be brought back to the transformers. This wire is a bit thicker and might be more difficult to hide. It is not intended for installation inside wall.

The LED disc is included with 36" of 24 gauge wire. An extension cord of 36" is available to extend that wire length. Multiple extension wires are permissible. The thin wire should be easy to hide. Neither wire is intended for installation inside walls.

Bringing Power to the Lighting

Determine from where the power will originate. Will you have one location for electric power or multiple?

A Disc system is powered via remotely located power supplies, whether hard-wired or plug-in. Wire travels from the fixtures to the power. Different power is needed for the LED system or the Xenon system. Following are details defined according to the system.

Xenon Disc System Power

Power to the Xenon Disc system is provided by an electronic transformer. Disc light bulbs are 20 watts. The 60 watt transformer will power one, two or three Xenon discs. Other sizes are available with multiples of the 60 watt transformer enclosed. The 180 watt transformer will power three sets of three discs. The 360 watt unit will power six sets of three discs. No more than three fixtures can be connected to an individual 60 watt power supply.

The Xenon disc fixtures are provided with 72" of wire. The individual wire must be brought back to the transformers. Power must be within the 72" length of each installed lighting unit.

LED Disc System Power

Power can be brought into an LED disc system in one of three ways, remote location, undercabinet mounted supply or plug-in. following are the benefits and detractions of each.

1. The remote power supply is the cleanest installation with the least amount of visual encumbrance. Once installed, only the power supply cable will be visible. The power supply unit is installed remote, so it can be hidden in a lower cabinet, the basement, the attic or atop the cabinets. Cable is rated for Class 2 installations, so it can travel inside the walls to the undercabinet surface. It is best if the ultimate location of the remote power supply is planned in advance. A “fish line” may be employed to aid in the passage of wire, once the walls are in position. A power supply cable is needed for this type installation.
2. An undercabinet mounted power supply can be used if power has already been installed. The source wire is pushed into the back of the wiring compartment, a wire connection is made and it is read to power the light fixture. Because of the size, this unit may have an undesirable aesthetic once installed. In over cabinet applications, this type of power supply will not be noticed and can be an effective method to adding light.
3. The disc systems can be powered with a cord and plug option. This should only be used as the last option when planning a permanent installation. A cord dangling down from a cabinet looks unkempt and unplanned. When planning a portable installation, such as a hutch or cabinet, a plug-in power source is the only viable alternative.

Driver Module (LED Disc Only)

Regardless of which power method is used, a driver module is required to operate the LED Disc system. One driver will operate three discs. Because of placement, you may prefer more that a 1:3 ratio of drivers to discs. Multiple drivers may be connected end-to-end or with Interconnect Cables.

Interconnect Cables (LED Disc Only)

Drivers can be linked together with interconnect cables. Determine if cables are needed to provide a continuous flow of power from driver to driver. If needed interconnect cables can pass through the wall, as they are Class 2 rated.

Switch Controls

Decide if a wall switch to control the lights is desired. If a wall switch that is configured into the 120 volt house current is also needed, this should be discussed with the electrician prior to the installation of the lighting fixtures.

The LED system also has a switch that will control the entire wired together system.

Night Light Module (LED Disc Only)

A night light is available for the LED systems. Determine if one or more are needed.

Check List and Spec List

Use the following list to insure proper communications prior to the job, all the parts needed for the job are captured and the installation is as expected afterwards.

Disc Cabinet Lighting System Check List and Spec List

Prior to the Job:

- Discuss the desired disc lighting system with the electrician.
- Discuss the desired power supply system with the electrician.
- Plan placement of the remote power supply, if used.
- Plan placement of interconnect cables that need to be buried behind the walls PRIOR to drywall installation.
- Discuss the desired 120V power switching needed with the electrician.
- Discuss the disc lighting system with the cabinet designer, retailer and installer.

Spec List LED Disc System [Design Pro LED Disc]

Description	Part No.	Finish	Qty	Location (N,S,E or W wall/cabinet)
4-W Disc	12310	BK, BRZ, NI, WH		
1-W Driver Module	12354	BK, WH		
Disc Extension Wire	12347	BK, WH		
9" cable	12341	BK, WH		
14" cable	12342	BK, WH		
21" cable	12343	BK, WH		
10'-0" cable	12344	BK, WH		
Dimming Switch	12350	BK, WH		
Night Light	12351	BK, WH		
Remote Power	12380	BK		

Supply 100W				
Remote Power Supply 200W	12382	BK		
Under Cabinet Power Supply 50W	12353	BK, WH		
Power Supply Lead 8'-0"	12344	BK, WH		
Power Supply Lead 25'-0"	12346	BK, WH		
Plug-in Power Supply 30W	12383	BK, WH		
Plug-in Power Supply 60W	12384	BK, WH		
Double Female Connector	12348	BK, WH		
Double Male Connector	12348	BK, WH		

Spec List Xenon Disc System [TaskWork Bright Disc 12V Xenon]

Description	Part No.	Finish	Qty	Location (N,S,E or W wall/cabinet)
20-W Disc	12501	BK, BZ, CO, NI, PB, WH		
Power Supply 60W	12531	BK		
Power Supply 180W (3x60)	12533	BK		
Power Supply 360W (6x60)	12534	BK		
Plug-in Power Supply 60W	12532	BK, WH		
Replacement Lamp	12590	CLR		

Planning a Kichler Linear Installation

Lighting architectural elements in the home using a linear system can add much impact, but developing a plan for installation is complicated. Because they are so different, the methodology for each system type is separate. For that reason, first determine if a Xenon festoon lamp system is desired or if an LED system is required. Refer to the previous chapters to help make this decision, but choice is typically divided into three areas:

1. Cost – the LED system will cost about twice the Xenon system
2. Size – The Xenon system is substantially larger than the LED version
3. Length – An LED system will travel, uninterrupted for 24'-0". If lengths are needed longer than this (without going back to the transformer and not including extension wire) than the Xenon system will be the answer.

Planning an LED Linear System

An LED linear system is a constant string of light with equidistant points of light that insure an even illumination across the length. The lumen output is typically not adequate for task illumination under a counter, but better suited for accent lighting inside and above cabinets and at toekicks. Coves, tray ceilings and other architectural detail can also be affectively lit with an LED linear system.

Determine Linear Lighting Length

Measure the linear length of what is to be illuminated. If lighting the inside of a cabinet, measure the inside length of the sides and top. (Lighting is typically not included at the base.) If an over cabinet area is to be lit, determine if the sides will be illuminated, or simply the front.

Only measure the area where light is required. If lighting will be skipping in a section or routed around an appliance or area, do not include that length. For example, if toekick light will not be used in front of a dishwasher, do not include the 36" of floor space in front of the dishwasher. Extension wire will be used to travel around the back of the appliance. Total all of the linear length of light to determine the length needed for the installation.

Determine Linear Length of Track and Whether It Is Needed

LED linear lighting can be installed with or without track. There is no right or wrong decision on the use of track, but there are some suggestions:

Use track when you:

- Want to insure a straight, linear flow of light
- If you are close to an adjoining surface. Even a fraction of an inch of variation will be noticed more, when proximity to light is close.

Track will be unnecessary if:

- Installation is on curved or rounded surfaces
- There are no closely adjoining reflective surfaces or walls
- Carefully measured pilot holes have been pre-drilled in the mounting surface, insuring straight, even light

Measure the linear length of light that you want assembled into a track. Track is sold in 3'-0" sections. Divide the length by the 3 to determine the amount of track needed. A few extra lengths may help avoid piecing together cut-offs or dropped sections for the last area.

Screws

If track is not used, screws will be needed to assemble the LED Linear lighting directly to the mounting surface. Screws are pre-installed in track sections and the LED fixtures snap into the track, so additional screws will not be needed.

Plan Wire Placement and Lengths Needed

Extension wire will be needed to connect the linear light lengths with the power supply. Extension wire will also be needed to move from one lighted area, over an unlit section and to the next lighted area. Total all of these unlit lengths to determine the length of extension wire needed.

Remember, when going around an appliance to measure the length to the rear wall, across the rear wall and then back up to the front of the cabinet. Leave a bit of extra wire to insure wire connection ease.

Bringing Power to the Lighting

Determine from where the power will originate. Will you have one location for electric power or multiple? Longer lengths will require larger power supplies. Calculate the placement and size of the transformer after having considered the length of light for the job.

Power can be brought into an LED linear system in one of three ways, remote, undercabinet mounted supply or plug-in. following are the benefits and detractions of each.

1. The remote power supply is the cleanest installation with the least amount of visual encumbrance. Once installed, only the power supply cable will be visible. The power supply unit is installed remote, so it can be hidden in a lower cabinet, the basement, the attic or atop the cabinets. Cable is rated for Class 2 installations, so it can travel inside the walls to the undercabinet surface. It is best if the ultimate location of the remote power supply is planned in advance. A "fish line" may be employed to aid in the passage of wire, once the walls are in position. A power supply cable is

needed for this type installation. Extension wire and the end of the LED linear can be brought directly into the remote power supply box, if not passing through a wall cavity. In this instance, the power supply cable would NOT be needed.

2. An undercabinet mounted power supply can be used if power has already been installed. Source 120V wire is pushed into the wiring compartment, a wire connection is made and it is ready to power the light fixture. Because of the size, this unit may have an undesirable aesthetic once installed. In over cabinet applications, this type of power supply will not be noticed and can be an effective method to adding light.
3. The linear systems can be powered with a cord and plug option. This should only be used as the last option when planning a permanent installation. A cord dangling down from a cabinet looks unkempt and unplanned. When planning a portable installation, such as a hutch or cabinet, a plug-in power source is the only viable alternative.

To transition from the plug end of the power supply cables and the undercabinet mounted power supply, an Interconnect Cable Transition Module will be needed. A male and female configuration is available.

Wire Connector Clips

When transitioning from the string of LED light to extension wire, connector clips will be needed. One wire end will need a male clip, the second side will need a female clip.

When transitioning from a string of LED light to the Interconnect Cable Transition Module, a male connector clip will be needed. All Interconnect Cable Transition Module have a female opening.

Determine if a “T” or “L” split of power is needed in the layout. This would occur if power needs to go in two directions. When transitioning from a string of LED light to the “T” Connector, a male connector clip will be needed. “T” Connectors have three female opening.

Total all of the male and female connectors needed to complete the job. In general, you will need more male connectors than female, because the female connector is already included in some of the accessory components.

Check List and Spec List

Use the following list to insure proper communications prior to the job, all the parts needed for the job are captured and the installation is as expected afterwards.

LED Linear Lighting System Check List and Spec List

Prior to the Job:

- Discuss the desired linear lighting system with the electrician.
- Discuss the desired power supply system with the electrician.
- Plan placement of the remote power supply, if used.
- Discuss the desired 120V power switching needed with the electrician.
- Discuss the linear lighting system with the cabinet designer, retailer and installer. Pass holes and wire routing accommodations might need to be added.

Spec List LED Linear System [Design Pro LED Linear]

Description	Part No.	Finish	Qty	Location (N,S,E or W wall/cabinet)
Linear LED – 12'-0" Spool	12320	BK, WH		
Track – 3'-0" section	12330	BK, WH		
Extension Wire	12323	BK, WH		
Wire Connector – Male	12332	BK		
Wire Connector – Female	12333	BK		
"T" Connector	12335	BK, WH		
Interconnect Cable Transition Module - Male	12338	BK, WH		
Interconnect Cable Transition Module - Female	12339	BK, WH		
Remote Power Supply 100W	12380	BK		
Remote Power Supply 200W	12382	BK		
Under Cabinet Power Supply 50W	12353	BK, WH		
Power Supply Lead 8'-0"	12344	BK, WH		
Power Supply Lead 25'-0"	12346	BK, WH		
Plug-in Power Supply 30W	12383	BK, WH		
Plug-in Power Supply 60W	12384	BK, WH		
Screws 100 for Black systems	10299	BK		
Screws 100 for White systems	10299	NI		

Planning an Kichler Xenon Linear System

A Xenon linear system is a continual length of wire onto which lamping is assembled. Lamps may be placed at any point along the length of wire. The lumen output of the higher wattage lamps is adequate for task illumination under a counter, but better suited for accent lighting inside and above cabinets and at toekicks. Coves, tray ceilings and other architectural detail can also be affectively lit with a Xenon linear system, typically employing the lower wattage lamps.

Determine Length of Linear Wire

Measure the linear length of what is to be illuminated. If lighting the inside of a cabinet, measure the inside length of the sides and top. (Lighting is typically not included at the base.) If an over cabinet area is to be lit, determine if the sides will be illuminated, or simply the front.

If lighting will be skipping a section or passing around an appliance or area, include that length. For example, if toekick light will not be used in front of a dishwasher, you must still include the wire needed to travel around the back of the appliance.

The wire must also travel from the location of the power supply to the intended location of the first lamp. Total all of the linear length of light to determine the length needed for the installation.

Wire End Caps add a finished look to the project and should be considered at any point where a cut end of linear wire is exposed.

Determine Linear Length of Track

Xenon linear **MUST** be installed with track. Lampholders lock into the track. Track is not needed in areas where lights will not be placed.

Measure the linear length where light will be assembled into a track. Track is sold in 4'-0" sections. Divide the length by the 4 to determine the amount of track needed. A few extra lengths may help avoid piecing together cut-offs or dropped sections for the last area.

Track End Caps add a finished look to the project and should be considered at any point where a cut ends of track are exposed.

Plan lighting Fixtures Needed

The amount of individual lights needs to be totaled. There are three "types" of available linear light.

1. festoon lamp holder with 5 watt lamp

2. festoon lamp holder with 10 watt lamp
3. Multi-directional lamp holder (20 watt lamps are sold separate)

A continuous flow of 5 watt lamps will provide a low lumen level perfect for accenting cabinet interiors and architectural elements. Lamps should be spaced 4" center-to-center.

A continuous flow of 10 watt lamps will provide a reasonable amount of light for counter tasks and will also work well for cabinet interiors and architectural elements. Lamps should be spaced 4" center-to-center.

Use the multi-directional lamps as a miniature spot light to draw attention to a specific item, such as a vase or collectable item. Lamps should be placed as needed.

If a continuous flow of light is not needed or desired, the lamps may be placed at any spacing desired. Count the total of lamps planned for the installation.

12V or 24V

A determination must be made whether to use a 12 volt power system or a 24 volt power system. A 12 volt system is generally better for a smaller amount of light that travels a shorter distance from power source to light. There is a maximum of 300 watts of load on one line. 24 volt systems are better when faced with long wire lengths and can support up to 600 watts on one line.

Bringing Power to the Lighting

Determine from where the power will originate. Will you have one location for electric power or multiple?

Total the lamp wattage used to illuminate the area.

Calculate the placement and size of the transformer along with the voltage that works for the application. There are a number of options, so care should be taken to select the right combination of voltage, wattage and case size.

If a wire junction fits into the plan, a block connector may be helpful. This allows for a "T" or "X" connection where the source power wire goes in one port on the connector and up to three can exit. An enclosure is also available.

Wire Stabilizer Clips

In areas where track will not be used (where no lamp will be installed) it is advisable to use stabilizer clips to hold the wire snug to the mounting surface and avoid sagging.

Check List and Spec List

Use the following list to insure proper communications prior to the job, all the parts needed for the job are captured and the installation is as expected afterwards.

Xenon Linear Lighting System Check List and Spec List

Prior to the Job:

- Discuss the desired linear lighting system with the electrician.
- Discuss the desired power supply system with the electrician.
- Plan placement of the power supply.
- Discuss the desired 120V power switching needed with the electrician.
- Discuss the linear lighting system with the cabinet designer, retailer and installer. Pass holes and wire routing accommodations might need to be added.

Spec List Xenon Linear System [TaskWork Linear 12V or 24V Xenon]

Description	Part No.	Finish	Qty	Location (N,S,E or W wall/cabinet)
Linear Wire 25'-0"	10230	BK, WH		
Linear Wire 100'-0"	10232	BK, WH		
Linear Wire 500'-0"	10233	BK, WH		
Linear Wire 1000'-0"	10234	BK, WH		
Wire End Cap	10240	BK, WH		
Track 10 pack	10283	BK, WH		
Track 50 pack	10243	BK, WH		
Track End Cap	10241	BK, WH		
In-line Light 12V 5W	10215	BK, WH		
In-line Light 12V 10W	10216	BK, WH		
In-line Light 24V 5W	10217	BK, WH		
In-line Light 24V 10W	10218	BK, WH		
Multi-Direction Fixture	10261	BK, WH		
Multi-Dir Lamp 12V 12°	10256	CLR		
Multi-Dir Lamp 12V 26°	10257	CLR		
Multi-Dir Lamp 24V 12°	10258	CLR		
Multi-Dir Lamp 24V 26°	10259	CLR		
Power Supply 12V 150W	10205	BK		
Power Supply 12V	10204	BK		

Power Supply 12V (2) 300W	10206	BK		
Power Supply 24V 300W	10208	BK		
Power Supply 24V 600W	10209	BK		
Power Supply 12V (2) 600W	10219	BK		
Power Supply 12V 150W Premium	10207	WH		
Power Supply 12V 300W Premium	10213	WH		
Power Supply 12V (2) 300W Premium	10211	WH		
Power Supply 12V 150W Electronic	10210	BK		
Power Supply 12V 75W Plug-in	10214	BK, WH		
Wire Block Connector	10244	BK, WH		
Wire Block Connector & Enclosure	10254	BK, WH		
Replacement In-line Lamp 12V 5 W	10245	CLR		
Replacement In-line Lamp 12V 5 W	10246	CLR		
Replacement In-line Lamp 12V 5 W	10247	CLR		
Replacement In-line Lamp 12V 5 W	10248	CLR		

Installation Tips

Each product is packaged with full installation instructions. This section is not intended to replace or supplant those instructions. This should simply provide supporting information to make a purchasing decision easier.

Tips are divided among the different types of lighting systems covered in this manual.

Modular Systems

A Typical LED Modular and Disc Installation Employing a Remote Power Supply

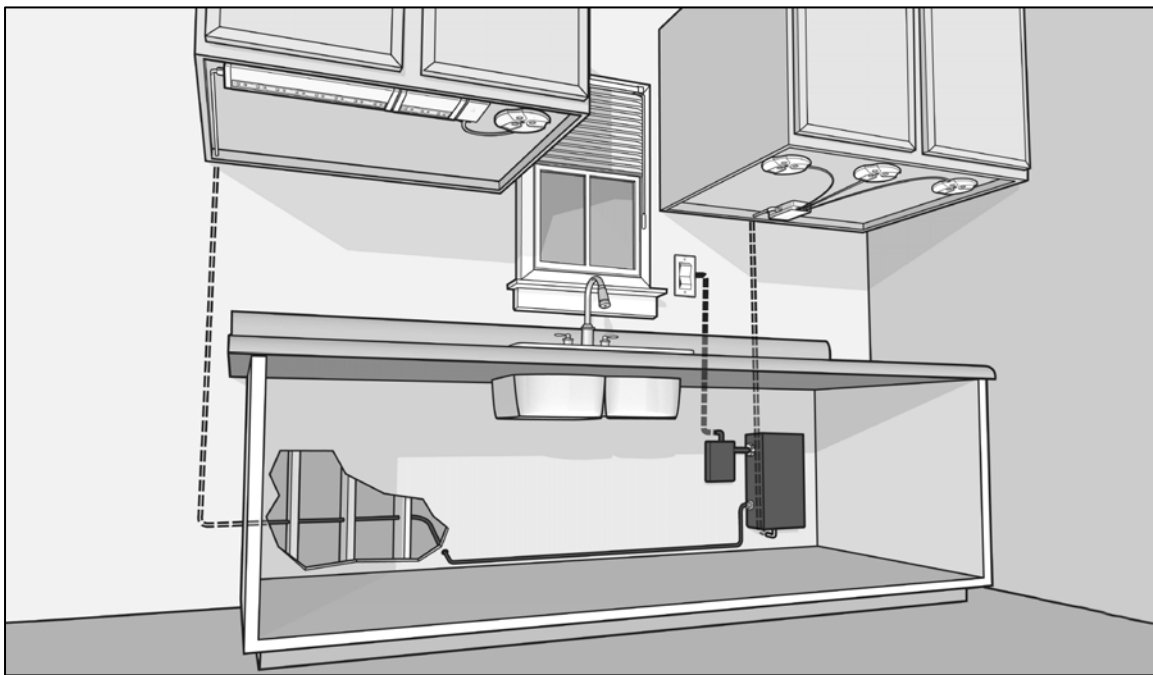

In this installation the remote power supply is located in the back of the lower cabinet. Power supply cables from both sides of the sink travel through the wall to the lower area and into the power supply box. The power supply box is controlled by a typical 120V wall switch. On the left side, note the closeness with which the power supply cable has been installed to the underside edge of the cabinet. This will be less visible. Also, remember, if this is a new installation, the path of the power cord wire can be plotted prior to the installation of the drywall if a “fish line” or false wire is positioned in the wall. Pulling the power cord will be easier. The power cord can, of course be installed, but passing the plug end through the rear panel of the cabinet might be problematic when the cabinets are installed.

LED Disc Systems

The biggest challenge with some LED discs installation is hiding the wire. Following are a few tips for a more aesthetically pleasurable installation.

The Design Pro LED Disc is very small, but placing the wire out of sight can be a challenge. For inside cabinet installations, where it is very likely that the wires will be visible, drill the wire passage hole **BEHIND** the disc. Once the disc is installed, it will be almost impossible to see the wire exiting the mounting surface behind the disc.

The top of cabinets or the top of shelving generally cannot be seen. These areas are perfect for making wire connections. Pass the wire through a hole in the top of the mounting surface and any required cable, power supply or connection can be made above and out of sight.

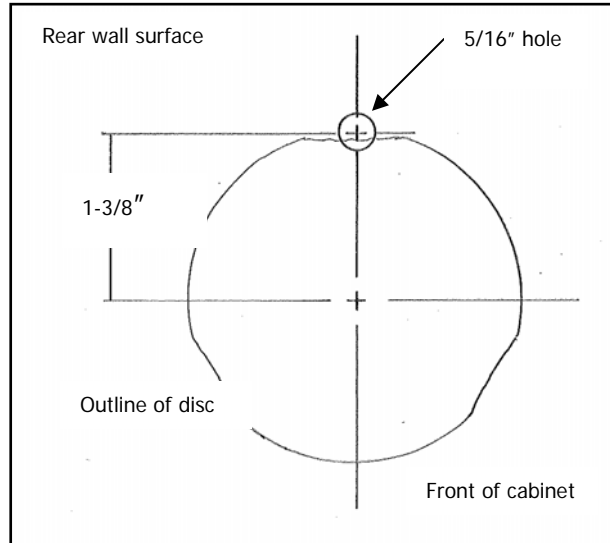

Use this concept in undercabinet installations as well, but remember the wire will end up on the bottom of the lower cabinet shelf. A false bottom may be needed to protect the wire from abrasion as the shelf is used. Do not use this method if the wire exposed to this wear. Dishware, glassware, canned goods or boxed goods, typically stored in a cabinet should not be allowed to rub against the electric wire. Wire should be protected.

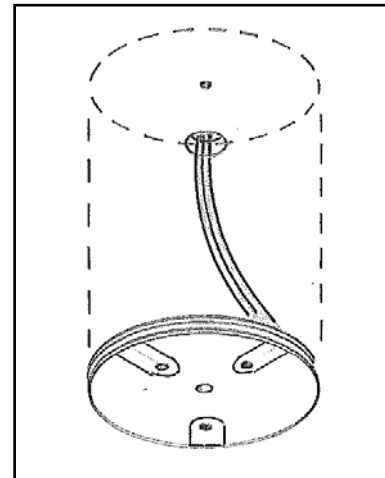

Interconnect Cable Notch

When connecting a modular light fixture from one undercabinet area to the next, it is likely that the cabinet dividers will need to be notched to accommodate the interconnect cable. There are a few different methods to notch the cabinet divider.

Create a simple tunnel in the wood divider. The cable diameter on the LED systems are x in diameter. The tunnel can be created by simply drilling a x hole very close to the edge of the wood and chiseling out the remains.

A more complex method of creating the pass hole involves a second step after the first suggestion. The X diameter hole is drilled 1/16" higher. After drilling the hole is chiseled out into a tunnel shape, then a router is used to create a flat area counter-bored below. This flat area will accommodate a shim that covers the wire hole and makes for a more finished look, when viewed from below.

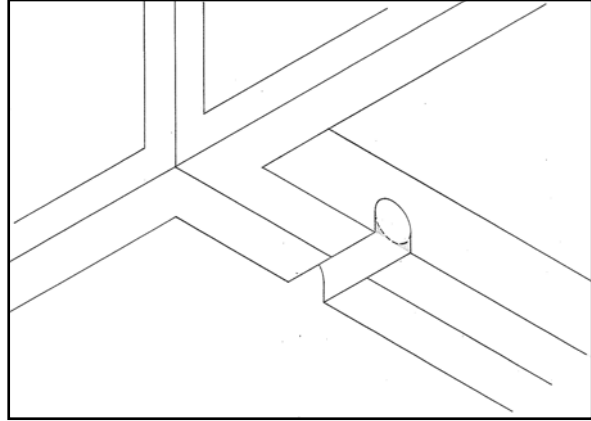

A third idea involves the notching out of a section of the cabinet divider. Once removed, a pass hole is cut out of the top section of the removed piece and the removed piece is positioned back with the interconnect cable pushed against the upper side of the cabinet and fully out of sight. This notch will create the cleanest look, but it is the most involved and should only be done by an accomplished cabinet maker.

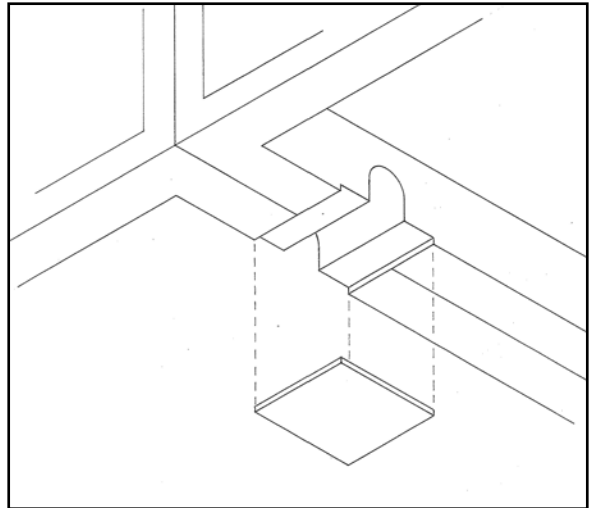

This method also works well when passing interconnect cables through the wall. In these cases, the plug head must remain, so the pass hole must be large enough to allow the plug to move through the wall. By removing and replacing a section of the wood, the large hole patch can be covered and the installation looks clean and professional.

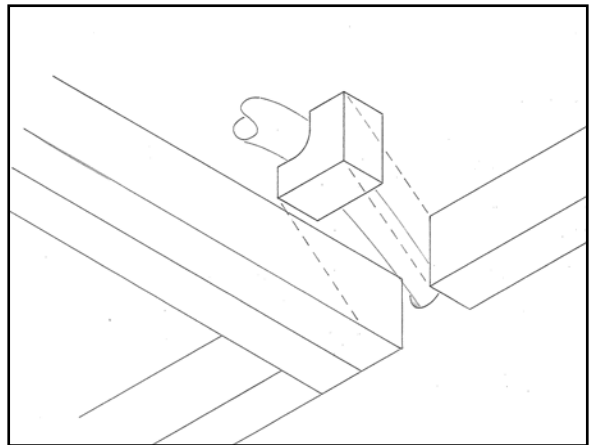

Frequently Asked Questions

Radio Interference

Q – Is it possible that radio waves will cause interference with under-cabinet lights?

A – It is possible and is rarely reported.

Q – I am experiencing radio interference with the cabinet lighting that includes a transformer (LED, 12V Xenon or Fluorescent.) What can be done?

A - The magnetic fields created by transformers sometimes interfere with the magnetic fields used to drive radio waves. Unfortunately, there are thousands of combinations of wavelengths and trying to determine which two will interfere is next to impossible. Here are a few things that can be done:

- The most serious interference is caused with AM radio signals. Switch to FM, if possible.
- Radio and Transformer on the same circuit will also heighten the possibility. If possible, move one.
- Physical proximity will cause a higher likelihood of inference. Move the radio farther away or reposition the radio, if possible.
- Are you certain it is the lighting? Many items in the kitchen have transformers. Even the phone charger emits magnetic waves. It might be something else or a combination of both.
- Try a filter. A number of commercially available filters are designed to reduce the affects of radio wave interference.

12V Xenon Bright Disc Power

Q – The higher wattage 12V Xenon Bright Disc Power Supplies are actually combinations of 60W transformers. Can I wire the individual 60W units together to achieve a higher single transformer power?

A – No. Both of the transformers are marked and instruction sheet state "Do not interconnect output terminations." These are class 2 transformers and run at the limiting class 2 current of 5 Amps. If these are interconnected...

1. Voids Class 2 rating
2. Voids UL listing
3. Voids Kichler Puck warranty - must be used with Kichler Class 2 power supply.
4. Likely to either fry a transformer because of the internal feedback or fry the light fixtures.

UL has established a 5A maximum on a Class 2 system. The UL listing we have for the fixtures ties them to a Class 2 power supply and therefore the 5A max. for the fixtures.

Q – How do others offer Puck lighting that can be powered by more than a 60 watt maximum power supply?

A – There are a number of reasons.

- They may not be offering a Class 2 system
- If they are running a 24V system, then each circuit could be 120 watts
- The units may not be covered by a UL listing

It may be necessary to consult the other vendors.

Kichler Design Pro LED Remote Power

Q – Why should a contractor use remote transformer layout in designing an under-cabinet installation?

A – Remote transformers provide the cleanest, best looking installation to match the virtually invisible slenderness of our lighting fixtures. This visual aid can also be used by contractors to help their customer understand that remote power is not a complex task, just different. See the “Modular Systems” sketch in the “Installation Tips” section of this manual for an easy to visualize explanation of remote wiring.

Q – Where and how are the Remote Power Supplies 12380BK (100w) and 12382BK (200w) installed?

A – The remote power supplies are engineered to be direct wire and wall mounted only. They can be located in basements, attics, or any well ventilated area that is convenient.

Additional facts:

- Input power is 120volt AC (alternating current) 50/60 Hz, output is 24volts DC (direct current). Terminal connection blocks are located inside housing for easy wiring connection.
- You can connect up to two of the Power Supply leads (that bring power to the lighting fixtures) in each terminal block on the secondary side.

Helpful hint:

- The 12382BK (200w) Power Supply contains two individual 100w power supplies inside housing. These operate independently and cannot be combined as one circuit. Both are UL listed Class II*.
- Dimensions are:

- 12380BK 11”H x 6 1/2” W x 3”D
- 12382BK 15 1/2”H x 11”W x 3”D

Q – How are Power Supply Leads 12344BK, WH & 12346BK, WH connected?

A – The Power Supply Leads are available in two lengths to accommodate most installations. The cable is UL listed, is Class II* and suitable to be run behind walls (Please check local codes for compliance). Cable should only be used to connect to Power Supplies. The cable contains a male connector on one end and a female connector on the other end.

When installing your system it is best to decide which end will be connected to the first fixture or power switch. Fixtures have a male connector on one end and a female connector on the other end. Once this has been decided, the other end of the connector is cut off. This allows for both a smaller opening in the wall and for hard wiring the connector to the power supply. The plug end can not be connected to the power supply.

Installation know-how:

This will also allow you to cut the cable shorter if the full length is not needed and run through the wall much easier. (Cable is approximately 1/4” diameter vs. plug-end at 1”dia.).

Helpful hint:

- Two Power Supply Leads can be connected if needed for extra long distance.

Q – Can I use any interconnect cable 12341,12342,12343,12345 to connect to the Power Supplies?

A – No. You cannot substitute any of the interconnect cables for the main power lead. These are specifically designed to a connection cable between under cabinet fixtures only.

These are a three (3) conductor wire cable (2 wires are for Positive and Negative 24 DC). The 3rd wire is a signal wire to control the light intensity when used with a Power Switch 12350BK, WH.

Helpful hint:

- Interconnect cables are available in 4 lengths and available in black and white.
 - 12341 is 9” in length
 - 12342 is 14” in length
 - 12343 is 21” in length
 - 12345 is 10’ (ft.) in length

Q – What does a Class 2 listing on a circuit mean?

A: An isolated secondary circuit involving not more than 42.2 volts (peak) with specific current limitations regarding wire size, de-rating factors, and over current protection. The voltage is limited to render the circuit safe from electrical shock, and the current is limited to render the circuit safe from fire.

The Class 2 circuit is the industry benchmark for electrical appliance safety.

Helpful hint:

- Kichler Design Pro LED under-cabinet lighting is listed as a Class 2 system and cannot be used with any other product or system in the market today. It is an exclusive Kichler design.

Q – Under which UL standard is the Kichler Design Pro LED listed?

A – UL 2108

Plug-in Power

Q – What is the length of the plug-in Power Supplies?

A – Both Plug-in Power Supplies (12383BK, WH and 12384BK, WH) are 48” in length.

Installation know-how:

- The 12383BK, WH will accommodate up to 30 watts and the 12384BK, WH will accommodate up to 60 watts. A male connector is molded to the end of the cable.

Helpful hint:

- A female to female accessory connector (12348BK, WH) is included in the carton when connecting two male ends is necessary.
- Plug-in Power supplies are UL Listed Class II.*

Kichler Design Pro System Design

Q – Why and when would I use connectors 12348BK, WH or 12349 BK, WH?

A – The 12348 and 12349 were designed to make a connection between two male ends or two female ends. In the event the wrong end was cut-off the Power Supply Lead 12344BK, WH, instead of purchasing a new lead you can supply the end user with a connector (12348/ 12349) to make the connection.

Helpful hint:

- These will also allow you to connect any two interconnects on the male to male or female to female ends.

Q – What is the purpose of the Power Switch 12350 BK, WH and is it required to the system?

A – The power switch 12350BK, WH was engineered to be a four position switch, including (1) Off, (2) Low, (3) Medium and (4) High. These settings are changed by gently tapping the switch to adjust the intensity of light. (This is why the 3rd wire on the interconnect cable is important).

Installation know-how:

- The Power Switch 12350 BK, WH is not required, but it is a convenient feature to include. You can just operate on the primary side by using a standard on/off switch that is wired in before the Power Supply 12380 or 12382.
- NOTE: By doing this you will only have one intensity of lighting; High.

Helpful hint:

- Also note that if you have a standard on/off switch before the Power Supply and are using the 12350BK, WH as well you can set the desired intensity using the 12350 and then turn the system on or off using the standard switch. The 12350 has a built in memory that will leave the setting as it was originally set.

Installation know-how:

- The 12351 BK, WH night light module can only be used with power switch 12350.

Q – Once I have all the Kichler LED fixtures linked together can I choose to turn one fixture off in the middle of a run?

A – Once all the fixtures are connected they will operate as one system. You cannot control one fixture independent of others on that same run.

Q – What combination or sizes should be used in a layout design?

A – Design Pro Series LED light fixtures are available in three sizes: 6", 12", and 18". We recommend filling the full length of a cabinet with light, to avoid shadows or dark spots where no light is placed. Any combination of sizes can be used. The fixtures can be linked together for extended flow of product for any project. Super slim Design Pro Series ultra thin ½" profile allows for easy concealment and versatile installation. Design Pro Series under cabinet light fixtures can be used below, above cabinets or under any shelf. The only limiter is the maximum

wattage size of the transformer. More detailed information on selecting size can be found in the “Planning A Modular System” section of this manual.

Q – How many 12347 3’ LED Disc wire extensions can be connected together?

A – We have tested 7 cords for a total of 21 feet and found no reduction in lumen output. If this extreme length of 21 feet is not enough the system layout should be revisited for improved efficiency.

Installation know-how:

- It is sometimes cleaner/easier to drill a hole near the perimeter of the disc and put the wire through the top or backside of the cabinet.

LED Dimming

Q – Can I use a standard or electronic wall dimmer to operate a Kichler LED Lighting system?

A – No. The Kichler LED system is not compatible with any dimming system. Further, it may be difficult for current dimming systems to operate most LED product offered today. A viable dimming method is now being researched.

LED Light

Q – To what is the light output of the Kichler Design Pro best compared?

A – The Design Pro Series was developed to produce light with the same color temperature as our Xenon under cabinet and linear product, which is approximately 3000 degrees Kelvin. The CRI is at, or greater than 90. Because Xenon light is somewhat “yellow,” you will find that the LED is somewhat “whiter.” The combination of a whiter light and high CRI will embolden most every color, especially purples, dark blues and deep reds.

Q – Why does one LED chip look like a different color compared to the chip next to it?

A – No two LED are exactly the same. Because we buy a range of chips there is variation from chip to chip. These variations are slight. The collective light output of the fixture is the best measure of color output.

LED Chips are manufactured and sorted into “bins” based on color temperature. The tighter the range of color requested, the more expensive the chip. Kichler purchases the tightest range of chips advertised. Our tolerance is $\pm 150K$ (Kelvin). Chip tolerance ranges from 2850K to 3150K for Kichler products. High brightness

LED chips used in Kichler Design Pro LED will make most every color “pop” much better than a typical Xenon lamp. Xenon is a more yellow light. Yellow trends to gray or wash out purples or blues close to purple on the color spectrum. High brightness LED chips are cleaner, whiter and make colors “jump”. It feels cooler, but it is not cool blue. Not as warm yellow as xenon.

Competitor LED color range is 875K – 1000K, some do not mention a range. These are the least desirable to a customer – they should steer clear as they have no idea what they will get.

Color variation is also present in incandescent and fluorescent bulbs. Fresh from the package they look the same, but with use or as they “burn” a dramatic color change occurs.

Helpful hint:

- Focus should be placed on the lumen output on the counter, the collective color.
- In room interiors where there is extensive use of white, and anything but a pure white (approximately 2700 Kelvin) specification is required, Kichler’s Xenon products may be a good alternative solution.

Q – How much energy does each LED chip consume used in a Kichler Design Pro lighting fixture and what can we do if one LED chip should happen to go out?

A – Each LED chip consumes approximately 1.3 watts of energy. If one should go out prematurely the entire fixture must be replaced. These cannot be serviced in the field. Please refer to the Kichler Warranty.

Energy Star

Q – Everyone has Energy Star listed light fixtures, don’t they?

A – Currently, Kichler was the first Energy Star solid state under-cabinet lighting listed and now is one of a VERY small group of Energy Star solid state cabinet lighting offered in America.

Sample Kitchen Layouts

On the following pages, there are three cabinet configurations you might have in a kitchen. A straight section of cabinets, an “L” shaped section of cabinets and a “U” shaped section. Using these templates, draw the assortment of cabinet sizes in your kitchen. Use small dotted lines, like those already on the “L” and “U” plan corners. Indicate the placement of any cabinet interruptions, such as windows, sinks, range or microwave.

To understand the drawings on the next few pages, use the sketch on this page to understand symbols used. If the sketches do not match your kitchen, use tracing paper and copy the illustration with appliances and cabinetry in the correct position.

30" Refrigerator
(36" is used on "L" and "U" shaped kitchens)

Hanging Cabinets

Double sink (27")

Hanging Cabinets

Range (30")

Hanging Cabinets

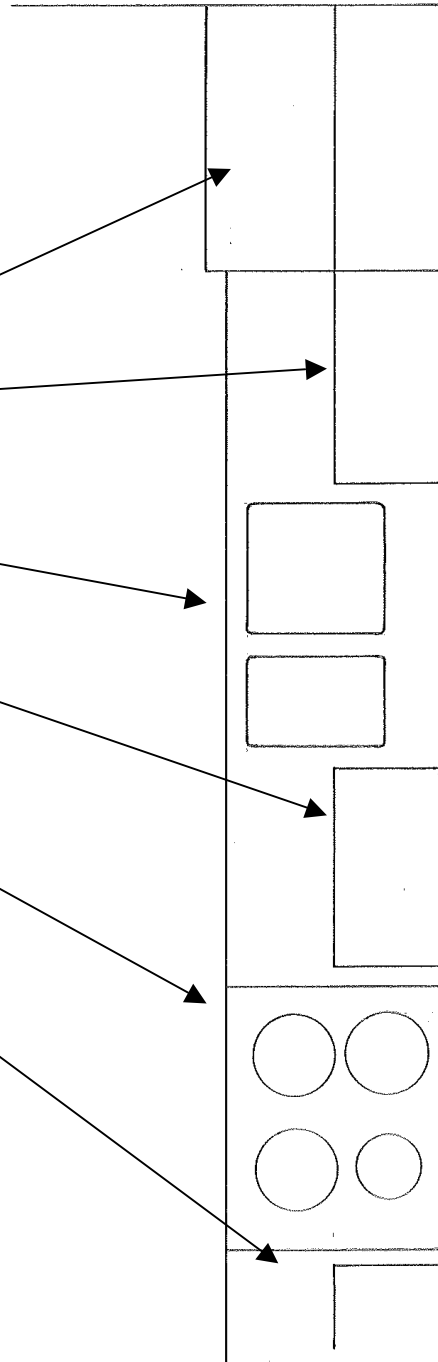

Galley (Straight) Kitchen Layout
Scale: 3/4" = 1'-0"

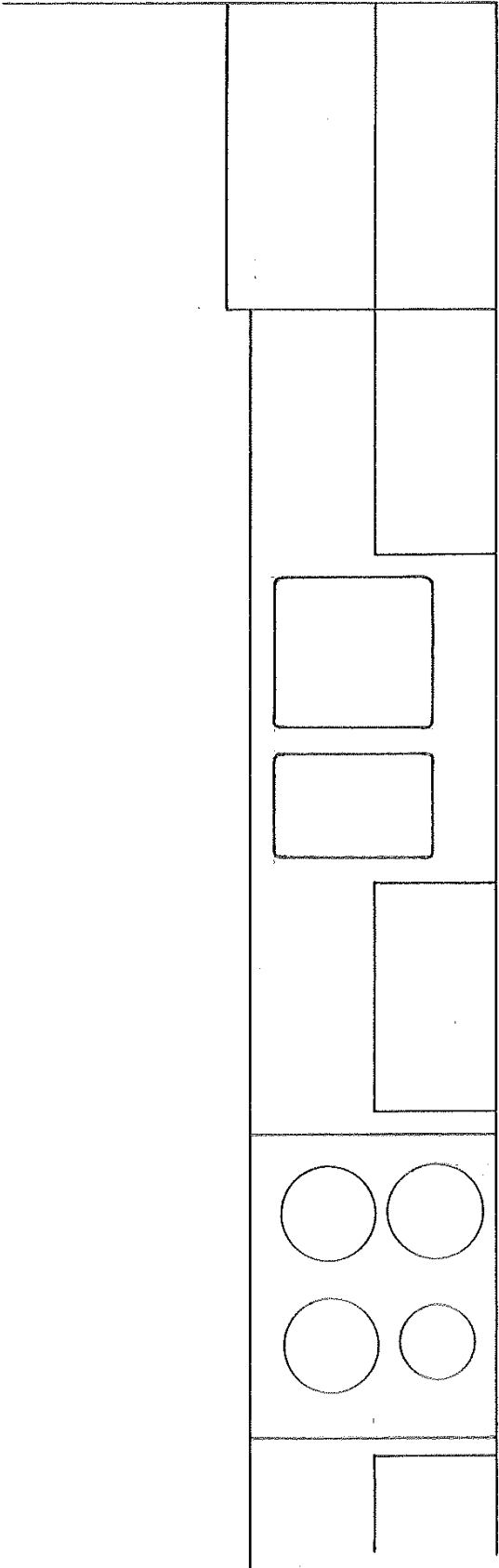

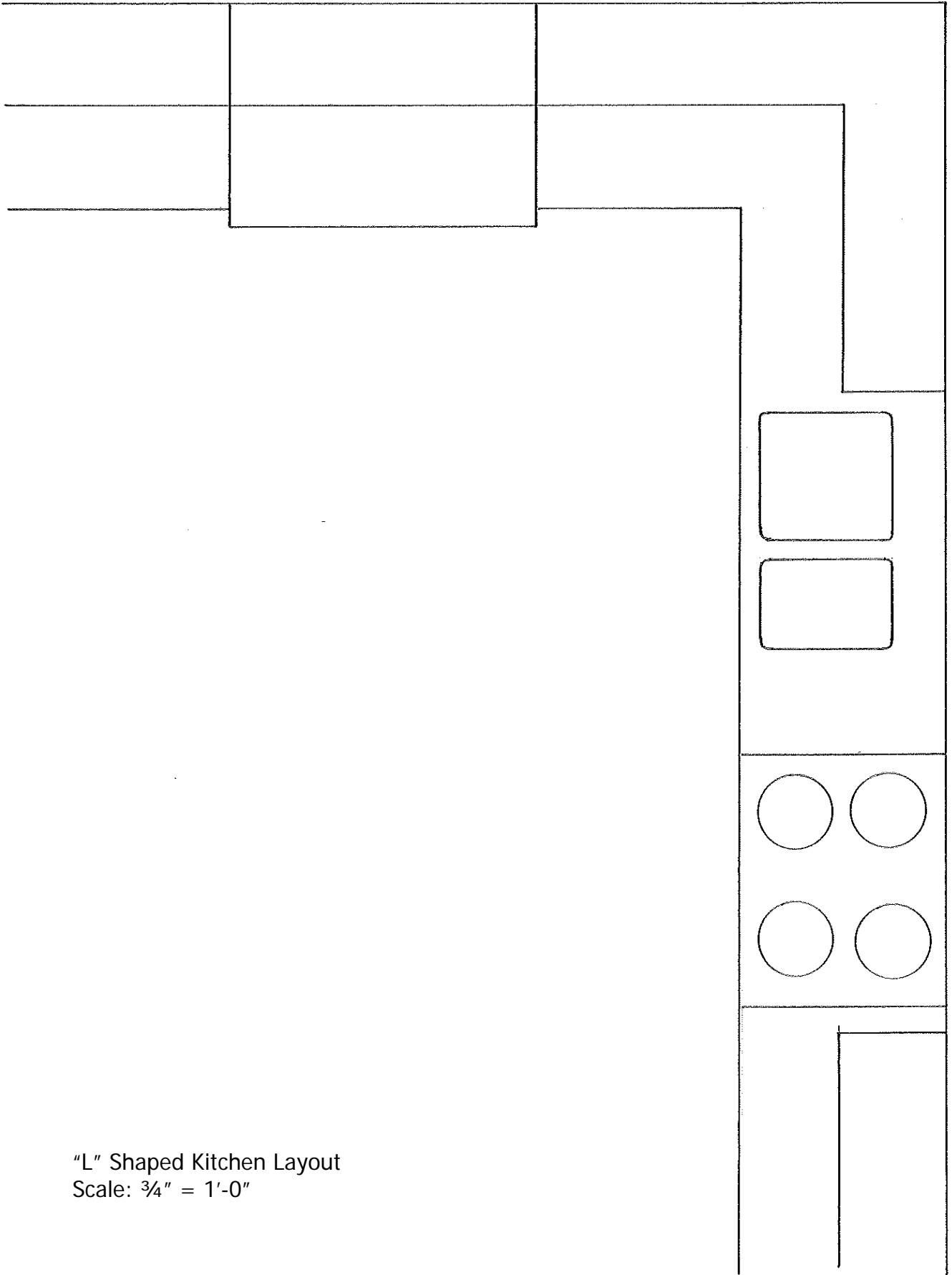

"L" Shaped Kitchen Layout
Scale: $\frac{3}{4}$ " = 1'-0"

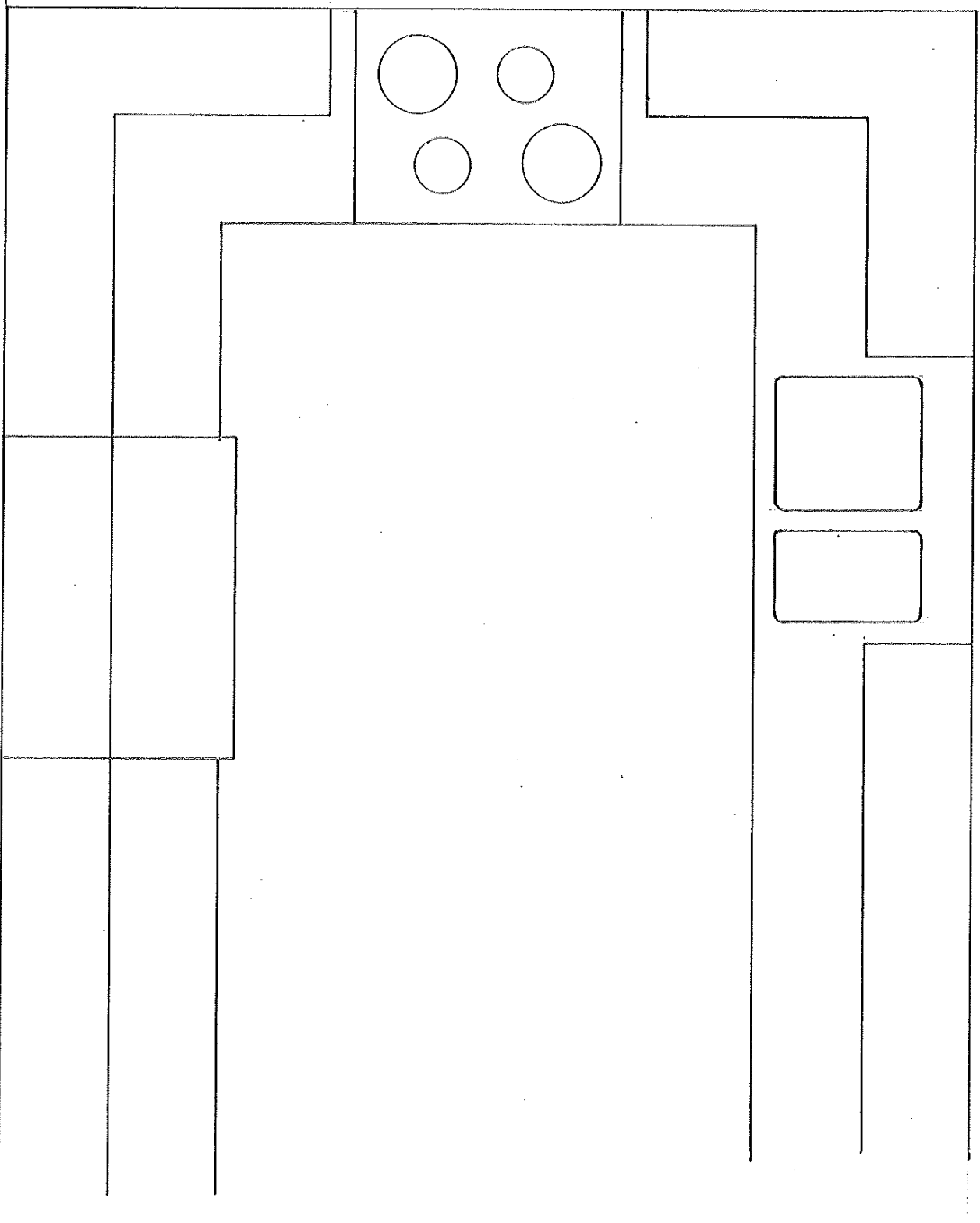

"U" Shaped Kitchen Layout
Scale: $\frac{3}{4}$ " = 1'-0"

Kichler Lighting
World Headquarters
7711 E Pleasant Valley Road
Cleveland, OH 44131-8010

Distribution Center:

- Atlanta, GA
- Cleveland, OH
- Las Vegas, NV

Where to Buy?

To find a dealer near you:

- Visit www.kichler.com on the Internet
- Click the “Where to Buy” tab
- The search radius defaults to 25 miles. Adjust this if desired
- Add your zip code
- A variety of local distributors will appear. Those indicated with a large blue starburst display the widest variety of Kichler goods.
- If the list is not adequate, try expanding the radius search

www.kichler.com

© Copyright All Rights Reserved.
Kichler Lighting 2009